

# 1 Project Information

|                |                        |
|----------------|------------------------|
| Project Title: | New EASE Focus Project |
| Date:          | 13 апреля 2022 г.      |
| Author:        |                        |
| Temperature:   | 20,0°C                 |
| Pressure:      | Standard (1010 hPa)    |
| Humidity:      | Standard (60%)         |
| Mapping:       | Broadband - A-Weighted |

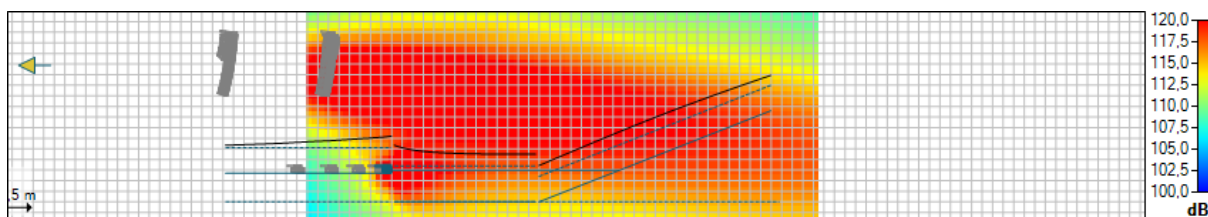
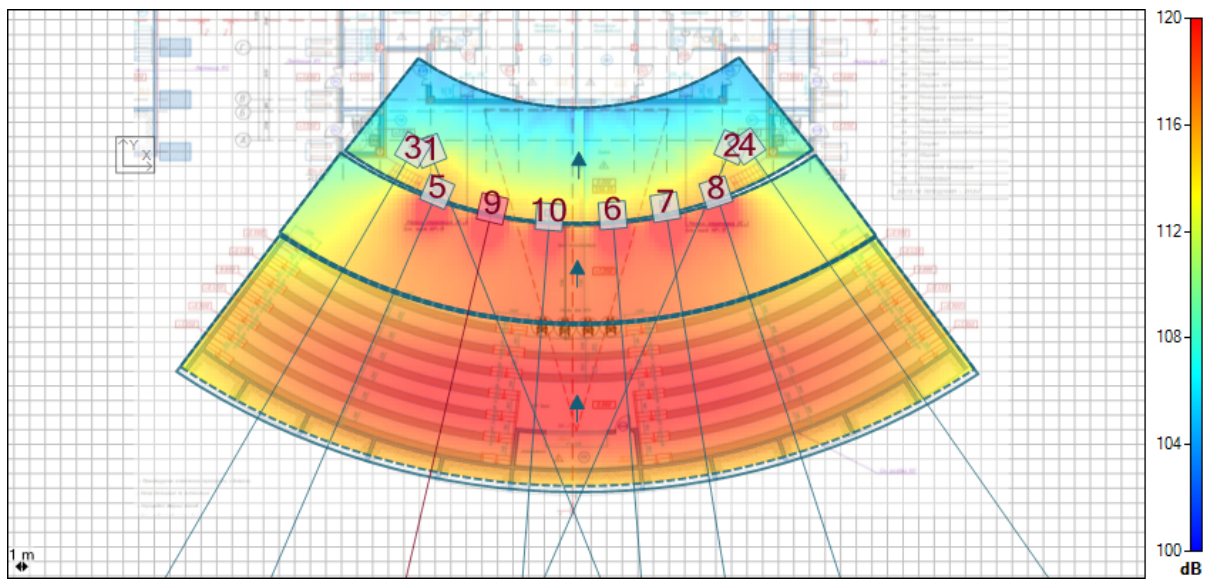

Side View: Ares8 3 1

## 2 Sound Sources

|    | Label     | Type       | System | X [m] | Y [m] | Z [m] | Hor [°] | Ver [°] | Rot [°] |
|----|-----------|------------|--------|-------|-------|-------|---------|---------|---------|
| 1  | Ares8     | Line Array | Ares8  | 19,64 | 0,43  | 8,00  | -68,2   | -5,2    | 0,0     |
| 2  | Ares8 1   | Line Array | Ares8  | 39,00 | 0,66  | 8,00  | -113,5  | -5,2    | 0,0     |
| 3  | Ares8 2   | Line Array | Ares8  | 18,57 | 0,50  | 7,85  | -120,1  | -5,9    | 0,0     |
| 4  | Ares8 2 1 | Line Array | Ares8  | 40,00 | 0,72  | 8,00  | -55,0   | -6,6    | 0,0     |
| 5  | Ares8 3   | Line Array | Ares8  | 20,13 | -2,18 | 1,74  | -113,3  | 0,0     | 0,0     |
| 6  | Ares8 3 1 | Line Array | Ares8  | 31,38 | -3,68 | 1,74  | -85,5   | 0,0     | 0,0     |
| 7  | Ares8 3 1 | Line Array | Ares8  | 34,75 | -3,16 | 1,74  | -80,8   | 0,0     | 0,0     |
| 8  | Ares8 3 1 | Line Array | Ares8  | 38,00 | -2,24 | 1,74  | -72,1   | 0,0     | 0,0     |
| 9  | Ares8 3 1 | Line Array | Ares8  | 23,67 | -3,27 | 1,74  | -103,2  | 0,0     | 0,0     |
| 10 | Ares8 3 1 | Line Array | Ares8  | 27,33 | -3,79 | 1,74  | -94,3   | 0,0     | 0,0     |

## 3 Distribution

Average: 115,5 dB  $\pm$ 4,2  
 Average - Std. Dev.: 111,3 dB  
 Average + Std. Dev.: 119,6 dB

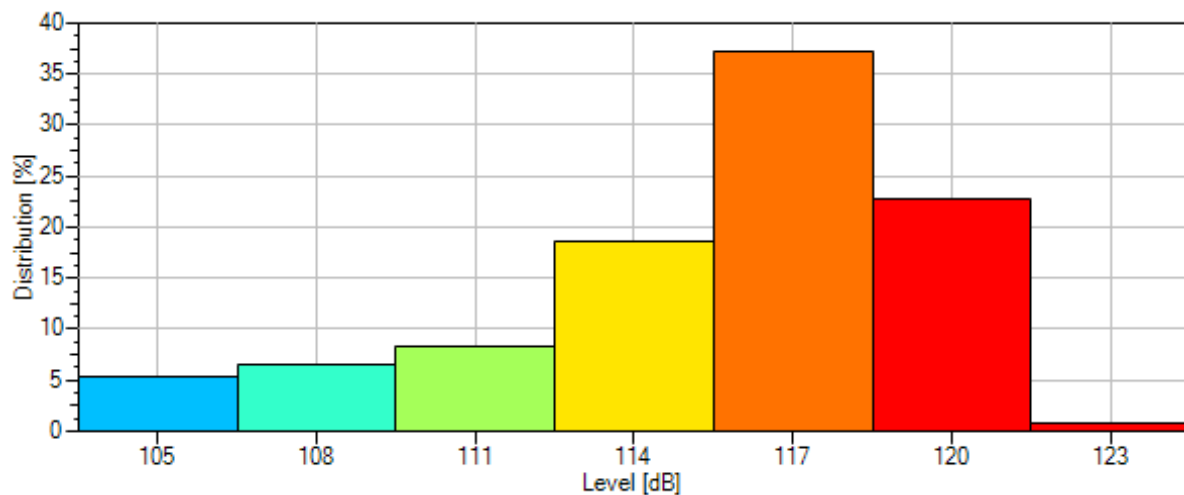

## 4 Sound Source - Ares8

|                           |                                   |
|---------------------------|-----------------------------------|
| System:                   | Ares8                             |
| Company:                  | AUDIOFOCUS                        |
| Label:                    | Ares8                             |
| Position:                 | X=19,64 m<br>Y=0,43 m<br>Z=8,00 m |
| Orientation:              | Hor=-68,2°<br>Ver=-5,2°           |
| Weight:                   | 368,00 kg                         |
| Setup:                    | Bumper                            |
| Box Count:                | 12                                |
| Pinpoint Mode:            | Best Pinpoint                     |
| Pinpoint Number:          | 7                                 |
| Remaining Vertical Angle: | -0,8°                             |
| Bottom Angle:             | 21,3 °                            |
| Above Ground:             | 4,98 m                            |

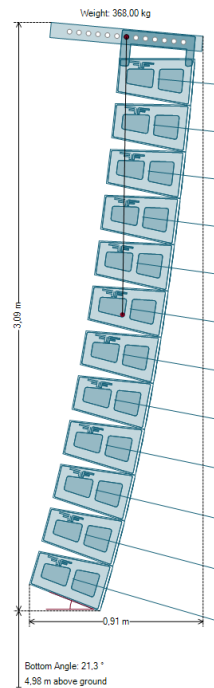

|        | Box Type | Gain   | Rigging Angle | Aiming Angle |
|--------|----------|--------|---------------|--------------|
|        | (Frame)  |        |               | -5,2°        |
| Box 1  | Ares8    | 0,0 dB | 0°            | -5,2°        |
| Box 2  | Ares8    | 0,0 dB | 1°            | -6,2°        |
| Box 3  | Ares8    | 0,0 dB | 0,5°          | -6,7°        |
| Box 4  | Ares8    | 0,0 dB | 0,5°          | -7,2°        |
| Box 5  | Ares8    | 0,0 dB | 0,5°          | -7,7°        |
| Box 6  | Ares8    | 0,0 dB | 1°            | -8,7°        |
| Box 7  | Ares8    | 0,0 dB | 1°            | -9,7°        |
| Box 8  | Ares8    | 0,0 dB | 1°            | -10,7°       |
| Box 9  | Ares8    | 0,0 dB | 1°            | -11,7°       |
| Box 10 | Ares8    | 0,0 dB | 1,5°          | -13,2°       |
| Box 11 | Ares8    | 0,0 dB | 1,5°          | -14,7°       |
| Box 12 | Ares8    | 0,0 dB | 1,5°          | -16,2°       |

|        | Box Type | Input Configuration | Input Types         |
|--------|----------|---------------------|---------------------|
|        | (Frame)  |                     |                     |
| Box 1  | Ares8    | Powersoft           | Powersoft: Preset 1 |
| Box 2  | Ares8    | Powersoft           | Powersoft: Preset 1 |
| Box 3  | Ares8    | Powersoft           | Powersoft: Preset 1 |
| Box 4  | Ares8    | Powersoft           | Powersoft: Preset 1 |
| Box 5  | Ares8    | Powersoft           | Powersoft: Preset 1 |
| Box 6  | Ares8    | Powersoft           | Powersoft: Preset 1 |
| Box 7  | Ares8    | Powersoft           | Powersoft: Preset 1 |
| Box 8  | Ares8    | Powersoft           | Powersoft: Preset 1 |
| Box 9  | Ares8    | Powersoft           | Powersoft: Preset 1 |
| Box 10 | Ares8    | Powersoft           | Powersoft: Preset 1 |
| Box 11 | Ares8    | Powersoft           | Powersoft: Preset 1 |
| Box 12 | Ares8    | Powersoft           | Powersoft: Preset 1 |

Filter Status: Active  
Gain: 0,0 dB  
Delay: 0,000 ms  
Polarity: Normal

Status  
No messages

## 5 Sound Source - Ares8 1

|                           |                                   |
|---------------------------|-----------------------------------|
| System:                   | Ares8                             |
| Company:                  | AUDIOFOCUS                        |
| Label:                    | Ares8 1                           |
| Position:                 | X=39,00 m<br>Y=0,66 m<br>Z=8,00 m |
| Orientation:              | Hor=-113,5°<br>Ver=-5,2°          |
| Weight:                   | 368,00 kg                         |
| Setup:                    | Bumper                            |
| Box Count:                | 12                                |
| Pinpoint Mode:            | Best Pinpoint                     |
| Pinpoint Number:          | 7                                 |
| Remaining Vertical Angle: | -0,8°                             |
| Bottom Angle:             | 20,8 °                            |
| Above Ground:             | 4,98 m                            |

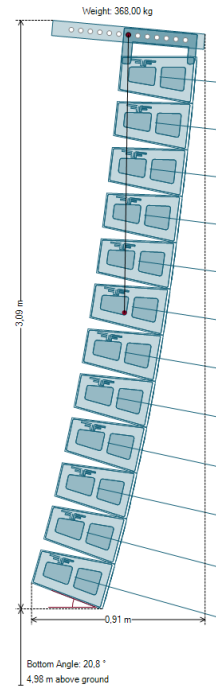

|        | Box Type | Gain   | Rigging Angle | Aiming Angle |
|--------|----------|--------|---------------|--------------|
|        | (Frame)  |        |               | -5,2°        |
| Box 1  | Ares8    | 0,0 dB | 0°            | -5,2°        |
| Box 2  | Ares8    | 0,0 dB | 1°            | -6,2°        |
| Box 3  | Ares8    | 0,0 dB | 0,5°          | -6,7°        |
| Box 4  | Ares8    | 0,0 dB | 0,5°          | -7,2°        |
| Box 5  | Ares8    | 0,0 dB | 0,5°          | -7,7°        |
| Box 6  | Ares8    | 0,0 dB | 1°            | -8,7°        |
| Box 7  | Ares8    | 0,0 dB | 1°            | -9,7°        |
| Box 8  | Ares8    | 0,0 dB | 1°            | -10,7°       |
| Box 9  | Ares8    | 0,0 dB | 1,5°          | -12,2°       |
| Box 10 | Ares8    | 0,0 dB | 0,5°          | -12,7°       |
| Box 11 | Ares8    | 0,0 dB | 2°            | -14,7°       |
| Box 12 | Ares8    | 0,0 dB | 1°            | -15,7°       |

|        | Box Type | Input Configuration | Input Types         |
|--------|----------|---------------------|---------------------|
|        | (Frame)  |                     |                     |
| Box 1  | Ares8    | Powersoft           | Powersoft: Preset 1 |
| Box 2  | Ares8    | Powersoft           | Powersoft: Preset 1 |
| Box 3  | Ares8    | Powersoft           | Powersoft: Preset 1 |
| Box 4  | Ares8    | Powersoft           | Powersoft: Preset 1 |
| Box 5  | Ares8    | Powersoft           | Powersoft: Preset 1 |
| Box 6  | Ares8    | Powersoft           | Powersoft: Preset 1 |
| Box 7  | Ares8    | Powersoft           | Powersoft: Preset 1 |
| Box 8  | Ares8    | Powersoft           | Powersoft: Preset 1 |
| Box 9  | Ares8    | Powersoft           | Powersoft: Preset 1 |
| Box 10 | Ares8    | Powersoft           | Powersoft: Preset 1 |
| Box 11 | Ares8    | Powersoft           | Powersoft: Preset 1 |
| Box 12 | Ares8    | Powersoft           | Powersoft: Preset 1 |

Filter Status: Active  
Gain: 0,0 dB  
Delay: 0,000 ms  
Polarity: Normal

Status  
No messages

## 6 Sound Source - Ares8 2

System: Ares8  
 Company: AUDIOFOCUS  
 Label: Ares8 2  
 Position: X=18,57 m  
 Y=0,50 m  
 Z=7,85 m  
 Orientation: Hor=-120,1°  
 Ver=-5,9°  
 Weight: 165,00 kg  
 Setup: Bumper  
 Box Count: 5  
 Pinpoint Mode: Best Pinpoint  
 Pinpoint Number: 6  
 Remaining Vertical Angle: 1,6°  
 Bottom Angle: 30,0 °  
 Above Ground: 6,54 m

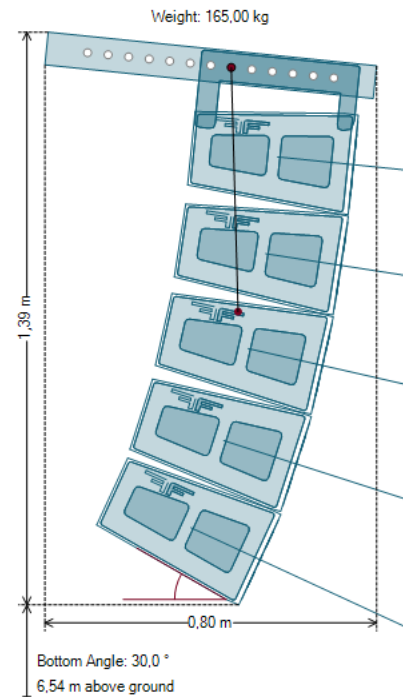

|       | Box Type | Gain   | Rigging Angle | Aiming Angle |
|-------|----------|--------|---------------|--------------|
|       | (Frame)  |        |               | -5,9°        |
| Box 1 | Ares8    | 0,0 dB | 0°            | -5,9°        |
| Box 2 | Ares8    | 0,0 dB | 3°            | -8,9°        |
| Box 3 | Ares8    | 0,0 dB | 4°            | -12,9°       |
| Box 4 | Ares8    | 0,0 dB | 5°            | -17,9°       |
| Box 5 | Ares8    | 0,0 dB | 7°            | -24,9°       |

|       | Box Type | Input Configuration | Input Types         |
|-------|----------|---------------------|---------------------|
|       | (Frame)  |                     |                     |
| Box 1 | Ares8    | Powersoft           | Powersoft: Preset 1 |
| Box 2 | Ares8    | Powersoft           | Powersoft: Preset 1 |
| Box 3 | Ares8    | Powersoft           | Powersoft: Preset 1 |
| Box 4 | Ares8    | Powersoft           | Powersoft: Preset 1 |
| Box 5 | Ares8    | Powersoft           | Powersoft: Preset 1 |

Filter Status: Active  
 Gain: 0,0 dB  
 Delay: 0,000 ms  
 Polarity: Normal

Status  
 No messages

## 7 Sound Source - Ares8 2 1

**System:** Ares8  
**Company:** AUDIOFOCUS  
**Label:** Ares8 2 1  
**Position:** X=40,00 m  
 Y=0,72 m  
 Z=8,00 m  
**Orientation:** Hor=-55,0°  
 Ver=-6,6°  
**Weight:** 165,00 kg  
**Setup:** Bumper  
**Box Count:** 5  
**Pinpoint Mode:** Best Pinpoint  
**Pinpoint Number:** 6  
**Remaining Vertical Angle:** 0,5°  
**Bottom Angle:** 32,8 °  
**Above Ground:** 6,70 m



|       | Box Type | Gain   | Rigging Angle | Aiming Angle |
|-------|----------|--------|---------------|--------------|
|       | (Frame)  |        |               | -6,6°        |
| Box 1 | Ares8    | 0,0 dB | 0°            | -6,6°        |
| Box 2 | Ares8    | 0,0 dB | 3,5°          | -10,1°       |
| Box 3 | Ares8    | 0,0 dB | 4°            | -14,1°       |
| Box 4 | Ares8    | 0,0 dB | 6°            | -20,1°       |
| Box 5 | Ares8    | 0,0 dB | 7,5°          | -27,6°       |

|       | Box Type | Input Configuration | Input Types         |
|-------|----------|---------------------|---------------------|
|       | (Frame)  |                     |                     |
| Box 1 | Ares8    | Powersoft           | Powersoft: Preset 1 |
| Box 2 | Ares8    | Powersoft           | Powersoft: Preset 1 |
| Box 3 | Ares8    | Powersoft           | Powersoft: Preset 1 |
| Box 4 | Ares8    | Powersoft           | Powersoft: Preset 1 |
| Box 5 | Ares8    | Powersoft           | Powersoft: Preset 1 |

**Filter Status:** Active  
**Gain:** 0,0 dB  
**Delay:** 0,000 ms  
**Polarity:** Normal

**Status**  
 No messages



## 8 Sound Source - Ares8 3

**System:** Ares8  
**Company:** AUDIOFOCUS  
**Label:** Ares8 3  
**Position:** X=20,13 m  
 Y=-2,18 m  
 Z=1,74 m  
**Orientation:** Hor=-113,3°  
 Ver=0,0°  
**Weight:** 49,00 kg  
**Setup:** Bumper  
**Box Count:** 1  
**Pinpoint Mode:** Best Pinpoint  
**Pinpoint Number:** 5  
**Remaining Vertical Angle:** 6,6°  
**Bottom Angle:** 5,1 °  
**Above Ground:** 1,37 m

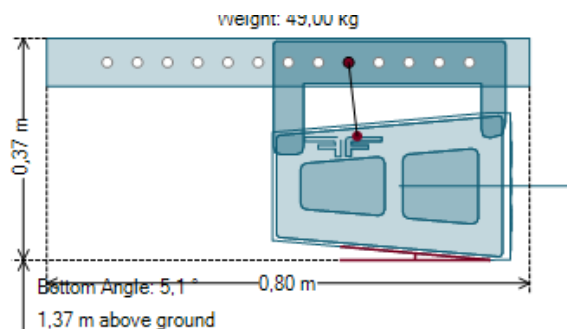

|       | Box Type | Gain   | Rigging Angle | Aiming Angle |
|-------|----------|--------|---------------|--------------|
|       | (Frame)  |        |               | 0,0°         |
| Box 1 | Ares8    | 0,0 dB | 0°            | 0,0°         |

|       | Box Type | Input Configuration | Input Types         |
|-------|----------|---------------------|---------------------|
|       | (Frame)  |                     |                     |
| Box 1 | Ares8    | Powersoft           | Powersoft: Preset 1 |

**Filter Status:** Active  
**Gain:** 0,0 dB  
**Delay:** 0,000 ms  
**Polarity:** Normal

**Status**  
 No messages

## 9 Sound Source - Ares8 3 1

**System:** Ares8  
**Company:** AUDIOFOCUS  
**Label:** Ares8 3 1  
**Position:** X=31,38 m  
 Y=-3,68 m  
 Z=1,74 m  
**Orientation:** Hor=-85,5°  
 Ver=0,0°  
**Weight:** 49,00 kg  
**Setup:** Bumper  
**Box Count:** 1  
**Pinpoint Mode:** Best Pinpoint  
**Pinpoint Number:** 5  
**Remaining Vertical Angle:** 6,6°  
**Bottom Angle:** 5,1 °  
**Above Ground:** 1,37 m

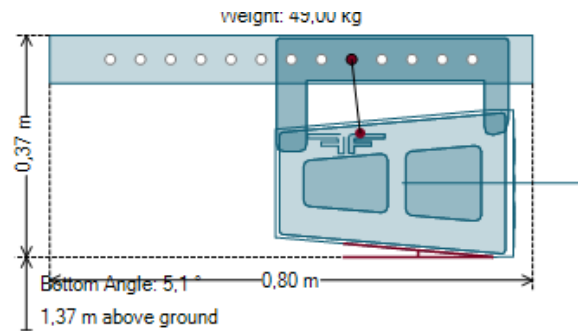

|       | Box Type | Gain   | Rigging Angle | Aiming Angle |
|-------|----------|--------|---------------|--------------|
|       | (Frame)  |        |               | 0,0°         |
| Box 1 | Ares8    | 0,0 dB | 0°            | 0,0°         |

|       | Box Type | Input Configuration | Input Types         |
|-------|----------|---------------------|---------------------|
|       | (Frame)  |                     |                     |
| Box 1 | Ares8    | Powersoft           | Powersoft: Preset 1 |

**Filter Status:** Active  
**Gain:** 0,0 dB  
**Delay:** 0,000 ms  
**Polarity:** Normal

**Status**  
 No messages

## 10 Sound Source - Ares8 3 1

System: Ares8  
 Company: AUDIOFOCUS  
 Label: Ares8 3 1  
 Position: X=34,75 m  
 Y=-3,16 m  
 Z=1,74 m  
 Orientation: Hor=-80,8°  
 Ver=0,0°  
 Weight: 49,00 kg  
 Setup: Bumper  
 Box Count: 1  
 Pinpoint Mode: Best Pinpoint  
 Pinpoint Number: 5  
 Remaining Vertical Angle: 6,6°  
 Bottom Angle: 5,1 °  
 Above Ground: 1,37 m

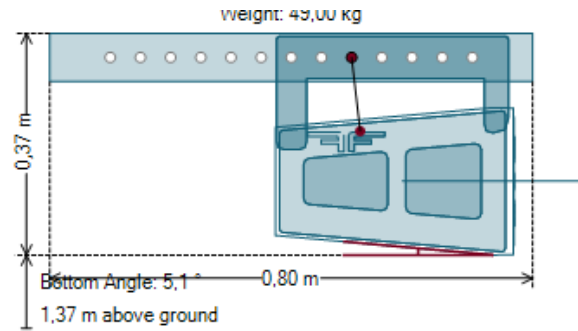

|       | Box Type | Gain   | Rigging Angle | Aiming Angle |
|-------|----------|--------|---------------|--------------|
|       | (Frame)  |        |               | 0,0°         |
| Box 1 | Ares8    | 0,0 dB | 0°            | 0,0°         |

|       | Box Type | Input Configuration | Input Types         |
|-------|----------|---------------------|---------------------|
|       | (Frame)  |                     |                     |
| Box 1 | Ares8    | Powersoft           | Powersoft: Preset 1 |

Filter Status: Active  
 Gain: 0,0 dB  
 Delay: 0,000 ms  
 Polarity: Normal

Status  
 No messages

## 11 Sound Source - Ares8 3 1

**System:** Ares8  
**Company:** AUDIOFOCUS  
**Label:** Ares8 3 1  
**Position:** X=38,00 m  
 Y=-2,24 m  
 Z=1,74 m  
**Orientation:** Hor=-72,1°  
 Ver=0,0°  
**Weight:** 49,00 kg  
**Setup:** Bumper  
**Box Count:** 1  
**Pinpoint Mode:** Best Pinpoint  
**Pinpoint Number:** 5  
**Remaining Vertical Angle:** 6,6°  
**Bottom Angle:** 5,1 °  
**Above Ground:** 1,37 m

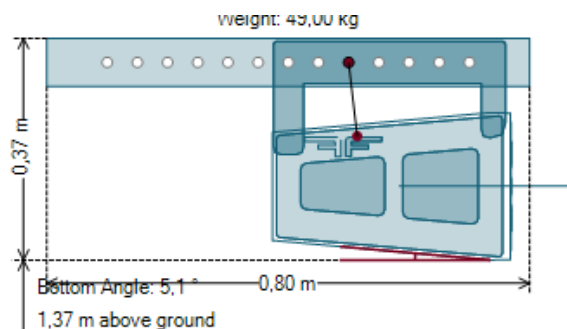

|       | Box Type | Gain   | Rigging Angle | Aiming Angle |
|-------|----------|--------|---------------|--------------|
|       | (Frame)  |        |               | 0,0°         |
| Box 1 | Ares8    | 0,0 dB | 0°            | 0,0°         |

|       | Box Type | Input Configuration | Input Types         |
|-------|----------|---------------------|---------------------|
|       | (Frame)  |                     |                     |
| Box 1 | Ares8    | Powersoft           | Powersoft: Preset 1 |

**Filter Status:** Active  
**Gain:** 0,0 dB  
**Delay:** 0,000 ms  
**Polarity:** Normal

**Status**  
 No messages

## 12 Sound Source - Ares8 3 1

**System:** Ares8  
**Company:** AUDIOFOCUS  
**Label:** Ares8 3 1  
**Position:** X=23,67 m  
 Y=-3,27 m  
 Z=1,74 m  
**Orientation:** Hor=-103,2°  
 Ver=0,0°  
**Weight:** 49,00 kg  
**Setup:** Bumper  
**Box Count:** 1  
**Pinpoint Mode:** Best Pinpoint  
**Pinpoint Number:** 5  
**Remaining Vertical Angle:** 6,6°  
**Bottom Angle:** 5,1 °  
**Above Ground:** 1,37 m

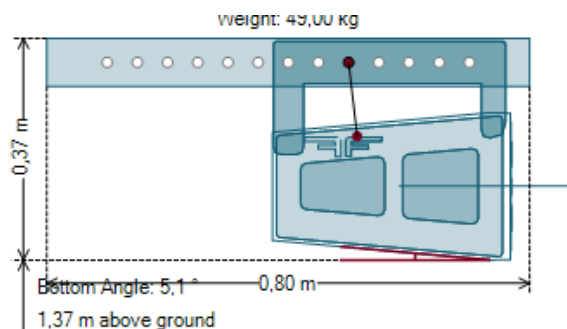

|       | Box Type | Gain   | Rigging Angle | Aiming Angle |
|-------|----------|--------|---------------|--------------|
|       | (Frame)  |        |               | 0,0°         |
| Box 1 | Ares8    | 0,0 dB | 0°            | 0,0°         |

|       | Box Type | Input Configuration | Input Types         |
|-------|----------|---------------------|---------------------|
|       | (Frame)  |                     |                     |
| Box 1 | Ares8    | Powersoft           | Powersoft: Preset 1 |

**Filter Status:** Active  
**Gain:** 0,0 dB  
**Delay:** 0,000 ms  
**Polarity:** Normal

**Status**  
 No messages

### 13 Sound Source - Ares8 3 1

**System:** Ares8  
**Company:** AUDIOFOCUS  
**Label:** Ares8 3 1  
**Position:** X=27,33 m  
 Y=-3,79 m  
 Z=1,74 m  
**Orientation:** Hor=-94,3°  
 Ver=0,0°  
**Weight:** 49,00 kg  
**Setup:** Bumper  
**Box Count:** 1  
**Pinpoint Mode:** Best Pinpoint  
**Pinpoint Number:** 5  
**Remaining Vertical Angle:** 6,6°  
**Bottom Angle:** 5,1 °  
**Above Ground:** 1,37 m

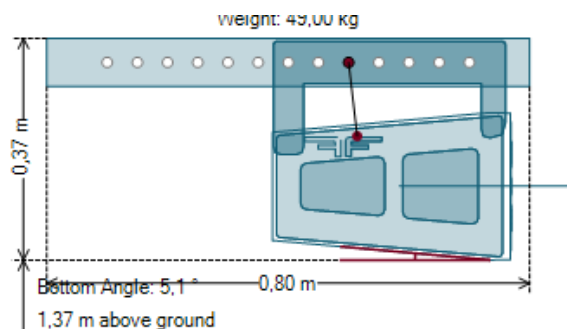

|       | Box Type | Gain   | Rigging Angle | Aiming Angle |
|-------|----------|--------|---------------|--------------|
|       | (Frame)  |        |               | 0,0°         |
| Box 1 | Ares8    | 0,0 dB | 0°            | 0,0°         |

|       | Box Type | Input Configuration | Input Types         |
|-------|----------|---------------------|---------------------|
|       | (Frame)  |                     |                     |
| Box 1 | Ares8    | Powersoft           | Powersoft: Preset 1 |

**Filter Status:** Active  
**Gain:** 0,0 dB  
**Delay:** 0,000 ms  
**Polarity:** Normal

**Status**  
 No messages

## 14 Audience Zone - Сцена

Label: Сцена  
Shape: Annular Sector

| Label | Length | Ear Height       |
|-------|--------|------------------|
| Сцена | 7,87 m | 1,20 m (Sitting) |

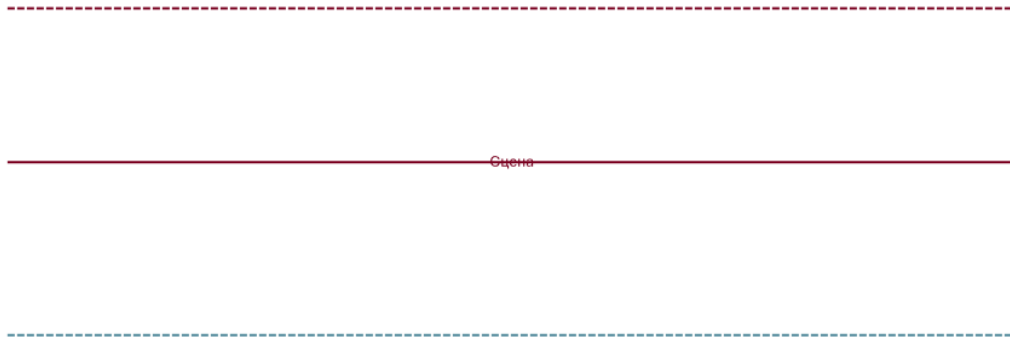

## 15 Audience Zone - Танцпол

Label: Танцпол  
Shape: Annular Sector

| Label   | Length | Ear Height        |
|---------|--------|-------------------|
| Танцпол | 6,70 m | 1,70 m (Standing) |





## 16 Audience Zone - Трибуна

Label: Трибуна  
Shape: Annular Sector

| Label   | Length  | Ear Height       |
|---------|---------|------------------|
| Трибуна | 11,81 m | 1,20 m (Sitting) |

